

A X I S

A250 (275kVA) Multi-Fuel Genset

Ultra Clean Energy with 50% Fuel Savings



The Axis A250Z is a cutting-edge, zero-emission, ultra-low fuel consumption 275kVA 3-phase multi-fuel, bio/diesel/natural gas/hydrogen generator designed for high-demand applications—from AI data centers to critical commercial backup. Powered by the innovative Axis A34B engine, a 3-liter super-turbo, dual-induced engine producing ~275bhp @ 1,500rpm, the A250Z delivers unmatched performance and reliability!

Built for longevity and engineered for efficiency, this (zero-emission ready) gen-set offers a sustainable power solution without compromising on output, with multi-fuel compatibility. Contact us today for pricing

Generator Specifications

- Maximum Power Rating: 275 kVA
- Minimum Power Rating: 250 kVA
- Voltage: 200 to 400 Volts
- Protection Class: IP23
- Frequency: 50 Hz / 60Hz
- Speed: 1,500 rpm
- Duty Cycle: Standby, Prime

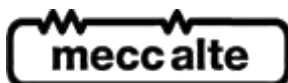

Engine Specifications

- Engine Model: **DuoFlux®** A34B-Z
- Engine Type: Axis 2-Cycle Dual Induction
- Bore: 99 mm | Stroke: 97.5 mm
- Displacement: 3 Liters
- Firing Order: 1-3-2-4
- EC Ratio: 34.5:1
- Aspiration: Forced Induction (super-turbo) after-cooled
- Fuel System: High-pressure direct injection
- Fuel consumption (@1,500rpm):
Natural Gas: ~1.56 kg per hour @ idle, 24kg per hour (full-load)
Hydrogen: ~0.65kg per hour @ idle, 10kg per hour (full-load)
Biodiesel: ~32litres per hour (full-load)



The A250 gen-set has three fuel connections as standard, Select the fuel type upon startup.

- Governor Type: Electronic
- Lubrication System: Wet Sump
- Exhaust System: Axis HRT-Manifold-SCR/CCR
- Cooling System: Mechanical/water-cooled

The A250Z gen-set comes with a 360-litre diesel tank as standard with an optional (100-litre) type-4 hydrogen or natural gas fuel tank. Mains fuel connection & bypass valves are included in the standard set.

Dimensions:

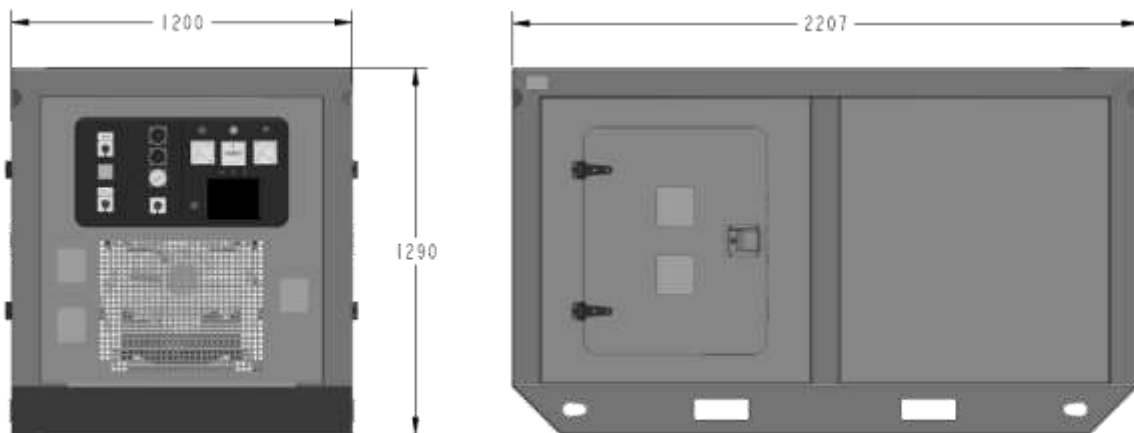

NET WEIGHT: ~1,535KG, **MAX WEIGHT:** 1,620KG

Disclaimer:

All performance figures stated are based on experimental data and are subject to change or update, as per ongoing company development. Axis gensets conform to: CEI 2-3, IEC 34-1, EN 60034-1, VDE 0530, BS 4999-5000, CAN/ CSA-C22.2 No14-95- No100-95.